

I GB D

► GENERAL CATALOGUE ◀

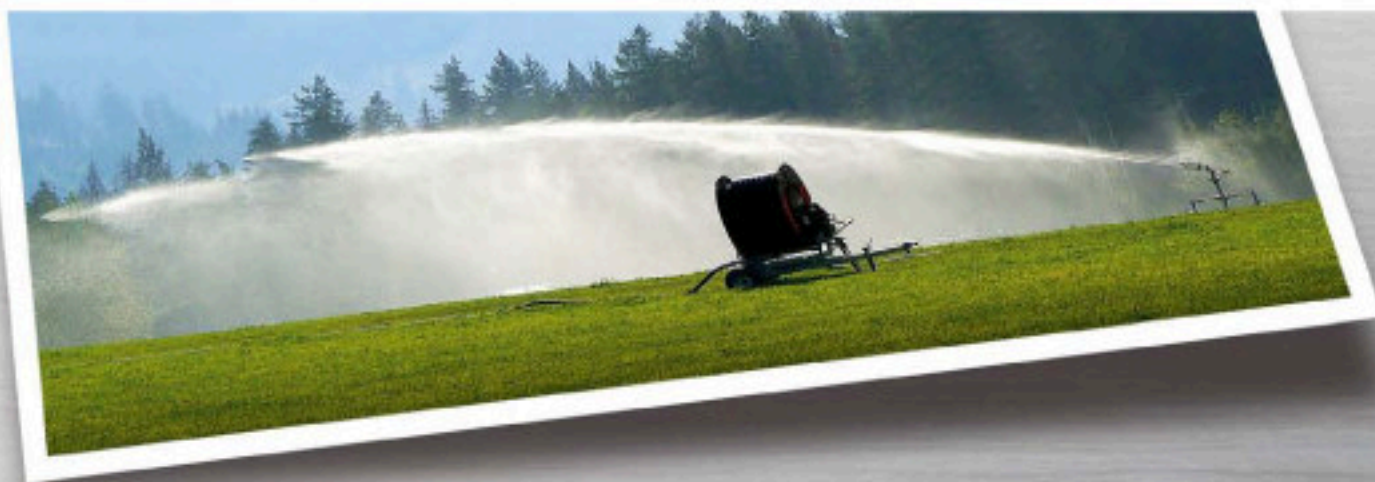

marani irrigation

marani-italy.com

M
MARANI
M

COMPANY PROFILE



La ditta **MARANI** nacque nel 1950 e la sua produzione principale si basava sui tubi in acciaio zincati e macchinari per irrigazione.

Ultimamente la ditta si è concentrata più sulla produzione di Macchine Irrigatrici semoventi con l'obiettivo di accrescere la sua presenza nel Mondo ogni giorno di più. Questa tendenza ha consentito a Marani di ampliare la sua gamma di prodotti sia in termini di macchine irrigatrici semoventi sia in termini di accessori di irrigazione quali gruppi motopompa e gruppi elettrogeni.

Marani è in grado di offrire una vasta gamma di macchine irrigatrici (circa 100) le quali possono essere equipaggiate con differenti accessori al fine di poter individuare sempre la soluzione ideale per il cliente finale. Marani è inoltre in grado di offrire una grande varietà di pompe centrifughe per acque chiare e scure. L'obiettivo principale di Marani è di garantire alla propria clientela i più alti standard qualitativi per quanto riguarda le materie prime e di conseguenza il prodotto finito. Questa rivoluzione in termini qualitativi si basa su un processo costante di miglioramento del prodotto finito. Ciò permetterà a Marani di raggiungere oltre ai più elevati standard qualitativi del suo prodotto, anche una posizione rilevante sia nel mercato nazionale sia in quello globale. Uno degli obiettivi di Marani è infatti quello di essere un attore di primo piano nel mercato dei rotoloni per il nuovo secolo.

MARANI was born in 1950, with its initial production being based on the production of galvanized steel pipe and on the production of irrigation machinery.

In the last period the company started to focus its resources on the production of HOSE REEL IRRIGATORS with the target to be every day more present all over the world. This focus made Marani enlarge its range of products in terms of hose reel irrigators as well as various irrigation accessories including motor pump units and gen sets.

Marani can offer a very big range of hose reel irrigators (more or less 100) that can be equipped with many different kind of accessories, in order to grant to the final customer the best solution for its requirements.

Marani can also offer a variety of pumps for tractors both for clean water and slurry as well as centrifugal pumps and overgears for thermal and electric motors.

The company main target is to guarantee to its customers the highest standards of quality in the raw materials and in the final product. This qualitative revolution is based on a continuous process of improvement of the product. This will enable Marani to reach a very good market position both in the Domestic Market and in the Global one. One of the main target of Marani is to be, in the new century, as a first class player.

Die Firma **MARANI** wurde im Jahr 1950 gegründet und ihre Hauptproduktion basiert auf Röhren aus verzinktem Stahl und Bewässerungsmaschinen.

In der letzten Zeit konzentrierte sich die Firma immer stärker auf die Produktion von selbstfahrenden Bewässerungsmaschinen und verfolgte dabei das Ziel, ihre Präsenz auf weltweiter Ebene immer weiter auszubauen. Diese Tendenz hat der Marani eine Erweiterung ihrer Produktreihe ermöglicht, dies sowohl was die selbstfahrenden Bewässerungsmaschinen als auch was das Bewässerungszubehör anbelangt, darunter Motorpumpen- und elektritätserzeugende Aggregate.

Marani bietet eine breite Palette an Bewässerungsmaschinen (ungefähr 100), die mit unterschiedlichen Zubehörtteilen ausgestattet werden können, so dass der Endkunde immer die ideale Lösung für seinen Anwendungsbereich finden wird. Im Angebot der Marani wird darüber hinaus eine große Anzahl an Kardanpumpen für Roh- und Schmutzwasser angeboten.

Das Hauptziel der Marani ist, ihren Kunden höchsten Qualitätsstandard nicht nur beim Endprodukt sondern bereits bei den Rohstoffen zu garantieren. Diese Revolution in Sachen „Qualität“ basiert auf einem konstanten Verbesserungsprozess des Endprodukts. Dies wird es der Marani ermöglichen, über das Erreichen der höchsten Qualitätsstandards hinaus auch eine bedeutende Position auf dem nationalen sowie auf dem internationalen Markt einnehmen zu können. Eines der Ziele bei Marani ist, immer ein Hauptbezugspunkt auf dem Markt der Bewässerungsmaschinen des neuen Jahrhunderts zu sein.

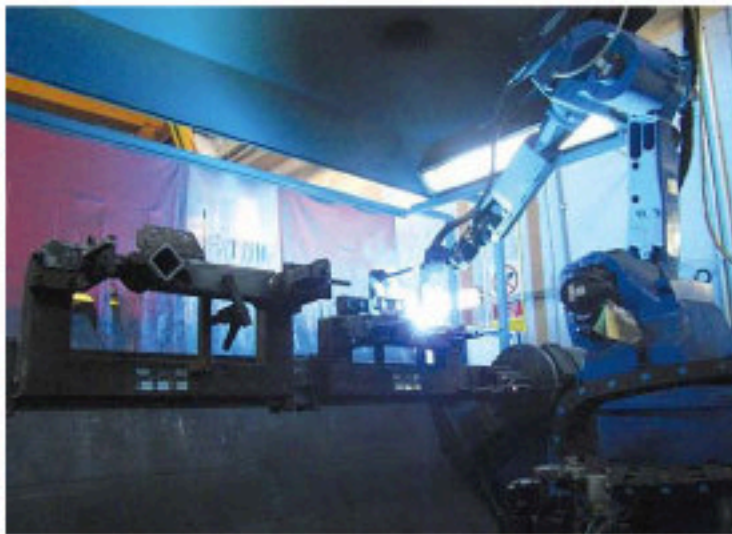

marani-italy.com

TURBO-GEARBOX

TURBO-RIDUTTORE:

Turbina con by pass incorporato flangiata direttamente al riduttore (In bagno d'olio) a 3, 4, 6 velocità. Sia la turbina che il riduttore sono stati progettati e realizzati utilizzando i materiali più nobili per garantire una lunga durata di esercizio e la migliori prestazioni di utilizzo. La trasmissione diretta, il riduttore con diverse marce e la turbina con by pass e regolatore di velocità, garantiscono le migliori prestazioni riducendo al minimo i consumi di energia.

TURBO-GEARBOX

Turbine with built-in by pass directly flanged with a 3,4,6 speed oil bath gearbox. Both Turbine and Gearbox are designed and produced using high quality material in order to grant longer life to the product it self and to grant better working conditions. The direct transmission, the different speed gearbox and the turbine with built-in by pass and speed regulator, gives better performance reducing energy costs.

TURBO-UNTERSETZUNGSGETRIEBE:

Direkt an das Untersetzungsgetriebe (im Ölbad gelagert) mit 3, 4 und 6 Geschwindigkeitsstufen geflanschte Turbine mit eingebautem By-Pass. Sowohl die Turbine als auch das Untersetzungsgetriebe wurden unter Einsatz der edelsten Materialien entworfen und realisiert, so dass sowohl eine lange Standzeit als auch die besten Einsatzleistungen gewährleistet werden können. Der Direktantrieb, das Untersetzungsgetriebe mit seinen verschiedenen Stufen, die Turbine mit ihrem By-Pass und der Geschwindigkeitsregler garantieren die besten Leistungen und reduzieren dabei den Energieverbrauch auf ein Minimum.

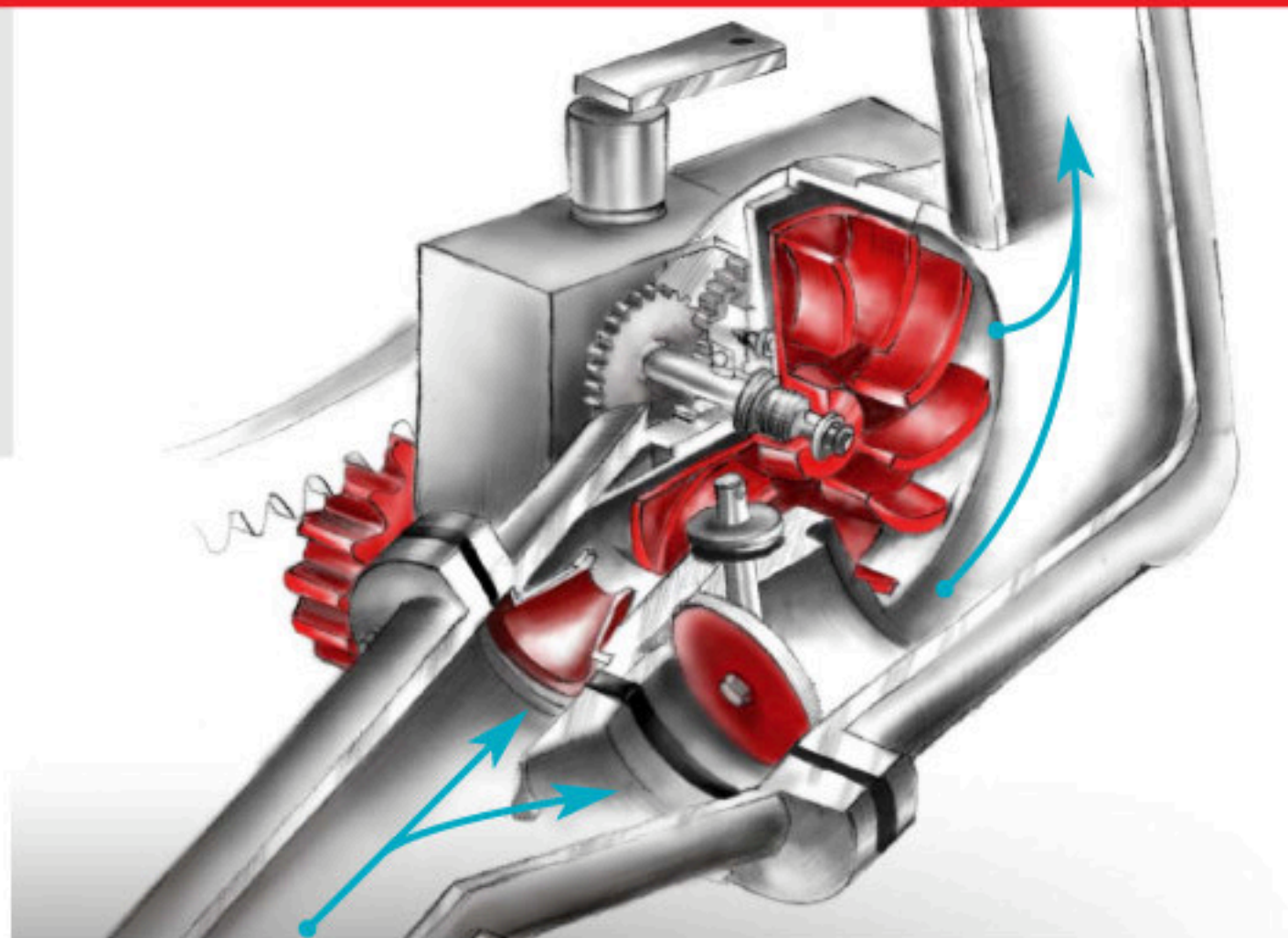

TELAIO:

In tubolare, saldato per mezzo di robot e zincato a caldo.

CHASSIS:

The chassis is made of electrowelded galvanised steel tubular pipes.

RAHMEN:

Aus Rohren, von Robotern verschweißt und heissverzinkt.

BOBINA:

In profilato, è supportata da cuscinetti a tenuta stagna.

DRUM:

Made of rugged frame design is supported by waterproof bearings.

SPULE:

Aus Profilen, auf wasserdichten Lagern gelagert.

CARRELLO PORTA IRRIGATORE:

a 2, 3, 4, 5 ruote, zincato a caldo e regolabile in larghezza ed altezza. Sono disponibili carrelli per speciali applicazioni.

RAIN GUN TROLLEY:

2, 3, 4 and 5 wheels galvanized trolley adjustable in high and width. Trolleys for special applications are available.

REGNERWAGEN:

Mit 2, 3, 4, 5 Rädern, heissverzinkt und sowohl höhen- als auch breitenverstellbar. Auch für Spezialapplikationen sind entsprechende Regnerwagen verfügbar.



marani-italy.com

TUBO:

In polietilene ad alta densità a spessore costante.

PIPE:

Hi density polyethylene pipe, with constant thickness.

SCHLAUCH:

Aus Niederdruck-Polyäthylen.

SISTEMA GUIDATUBO:

Garantisce il giusto bobinamento del tubo sulla macchina per mezzo di vite senza fine.

HOSE GUIDE SYSTEM:

The correct winding of the pipe in the drum is granted by using a scroll bar system.

SCHLAUCHFÜHRUNGSSYSTEM:

Garantiert die richtige Schlauchaufwicklung auf der Maschine über eine Schnecke.

DOPPIA ENTRATA DELL' ACQUA:

Per consentire l' irrigazione di campi contrapposti senza lo spostamento della macchina.

DOUBLE WATER INLET:

Double water inlet in order to irrigate opposite fields without moving the machine.

DOPPELTER WASSEREINLASS

Ermöglicht die Bewässerung von gegenüberliegenden Feldern, ohne dass die Maschine dazu verfahren werden muss.

F010B - GT015B



GT015B



F010B



Modello Model Modelle	Ø	mt	Irrigatore Raingun Regner	Boccali Nozzles Düsen
F010B	40	130	K1	8/9/10
	43	120	K1	9/10/12
	50	170	HYDRA	12/14/16
	58	140	HYDRA	14/16/18
	63	100	HYDRA	14/16/18
GT015B	50	230	HYDRA	10/12/14
	58	200	HYDRA	14/16/18

GT020B - GT022B



GT020B



GT022B

marani-italy.com

Modello Model Modelle	Ø	mt	Irrigatore Raingun Regner	Bocchigli Nozzles Düsen
GT020B	50	250	HYDRA	12/14/16
	58	250	HYDRA	14/16/18
	63	200	DUPLEX	14/16/18
	70	150	SYNKRO	16/18/20
GT022B	63	250	DUPLEX	14/16/18
	63	280	DUPLEX	14/16/18
	63	300	DUPLEX	14/16/18
	70	220	SYNKRO	16/18/20
	70	270	SYNKRO	16/18/20
	75	220	SYNKRO	16/18/20
	75	250	SYNKRO	16/18/20
82	180	SYNKRO	18/20/22	

Accessori non inclusi - Accessories not included - Zubehör nicht inbegriffen

GT026B - GT030B



GT026B



GT030B



Modello Model Modelle	Ø	mt	Irrigatore Raingun Regner	Boccapil Nozzles Düsen
GT026B	70	350	SYNKRO	16/18/20
	75	300	SYNKRO	16/18/20
	75	330	SYNKRO	16/18/20
	82	270	SYNKRO	18/20/22
	82	300	SYNKRO	18/20/22
	90	220	RANGER	24/26/28
GT030B	75	350	SYNKRO	16/18/20
	75	400	SYNKRO	16/18/20
	82	350	SYNKRO	18/20/22
	82	400	SYNKRO	18/20/22
	90	280	RANGER	24/26/28
	90	300	RANGER	24/26/28
	90	350	RANGER	22/24/26
	100	275	RANGER	26/28/30

Accessori non inclusi - Accessories not included - Zubehör nicht inbegriffen

GT040B - GT040C



GT040C



GT040B

marani-italy.com

Modello Model Modelle	Ø	mt	Irrigatore Raingun Regner	Bocchigli Nozzles Düsen
GT040B	82	500	SYNKRO	16/18/20
	90	370	RANGER	24/26/28
	90	400	RANGER	24/26/28
	90	450	RANGER	22/24/26
	90	480	RANGER	22/24/26
	100	300	RANGER	26/28/30
	100	330	RANGER	26/28/30
	100	350	RANGER	26/28/30
	110	250	RANGER	28/30/32
GT040C	110	300	RANGER	28/30/32
	110	320	RANGER	28/30/32

**GT050B - GT060B
GT070B**



Modello Model Modelle	Ø	mt	Irrigatore Raingun Regner	Boccapil Nozzles Düsen
GT050B	90	500	RANGER	22/24/26
	100	400	RANGER	22/24/26
	110	300	RANGER	28/30/32
	110	330	RANGER	28/30/32
	110	350	RANGER	26/28/30
	125	250	EXPLORER	32/34/36
GT060B	100	450	RANGER	26/28/30
	100	500	RANGER	26/28/30
	110	400	RANGER	28/30/32
	110	420	RANGER	28/30/32
	110	450	RANGER	28/30/32
	120	380	EXPLORER	32/34/36
	125	300	EXPLORER	32/34/36
	125	350	EXPLORER	32/34/36

Modello Model Modelle	Ø	mt	Irrigatore Raingun Regner	Boccapil Nozzles Düsen
GT070B	100	550	RANGER	26/28/30
	100	600	RANGER	26/28/30
	110	500	RANGER	28/30/32
	110	530	RANGER	28/30/32
	110	550	RANGER	28/30/32
	120	440	EXPLORER	32/34/36
	125	380	EXPLORER	32/34/36
	125	400	EXPLORER	32/34/36
	125	420	EXPLORER	32/34/36
	135	350	EXPLORER	34/36/38
	135	370	EXPLORER	34/36/38
	140	300	EXPLORER	34/36/38
140	350	EXPLORER	34/36/38	

Accessori non inclusi - Accessories not included - Zubehör nicht inbegriffen

GTS080B



marani-italy.com

Modello Model Modelle	Ø	mt	Irrigatore Raingun Regner	Bocagli Nozzles Düsen
GTS080B	100	650	RANGER	26/28/30
	110	550	RANGER	24/26/28
	110	600	RANGER	24/26/28
	120	540	EXPLORER	30/32/34
	125	450	EXPLORER	32/34/36
	125	500	EXPLORER	32/34/36
	135	400	EXPLORER	34/36/38
	140	380	EXPLORER	36/38/40

GTS090B



Modello Model Modelle	Ø	mt	Irrigatore Raingun Regner	Boccali Nozzles Düsen
GTS090B	110	650	RANGER	24/26/28
	110	700	RANGER	26/28/30
	120	600	EXPLORER	28/30/32
	120	650	EXPLORER	28/30/32
	125	550	EXPLORER	32/34/36
	125	600	EXPLORER	30/32/34
	135	500	EXPLORER	34/36/38
	140	450	EXPLORER	34/36/38
	140	470	EXPLORER	34/36/38

Accessori non inclusi - Accessories not included - Zubehör nicht inbegriffen

IT040B - IT050B IT060B - IT070B



Modello Model Modelle	Ø	mt	Irrigatore Raingun Regner	Bocchigli Nozzles Düsen
IT040B	90	370	RANGER	24/26/28
	90	400	RANGER	22/24/26
	90	450	RANGER	22/24/26
	90	480	RANGER	22/24/26
	100	300	RANGER	26/28/30
	100	330	RANGER	26/28/30
	100	350	RANGER	24/26/28
	110	250	RANGER	28/30/32
	110	300	RANGER	28/30/32
	110	320	RANGER	28/30/32

Modello Model Modelle	Ø	mt	Irrigatore Raingun Regner	Bocchigli Nozzles Düsen
IT050B	90	500	RANGER	22/24/26
	100	400	RANGER	26/28/32
	110	300	RANGER	28/30/32
	110	330	RANGER	28/30/32
	110	350	RANGER	26/28/30
	125	250	EXPLORER	32/34/36
IT060B	100	450	RANGER	24/26/28
	100	500	RANGER	22/24/26
	110	400	RANGER	26/28/30
	110	420	RANGER	26/28/30
	110	450	RANGER	26/28/30
	120	380	EXPLORER	30/32/34
	125	300	EXPLORER	32/34/36
	125	350	EXPLORER	32/34/36

Modello Model Modelle	Ø	mt	Irrigatore Raingun Regner	Bocchigli Nozzles Düsen
IT070B	100	550	RANGER	22/24/26
	100	600	RANGER	22/24/26
	110	500	RANGER	26/28/30
	110	530	RANGER	26/28/30
	110	550	RANGER	26/28/30
	120	440	EXPLORER	30/32/34
	125	380	EXPLORER	32/34/36
	125	400	EXPLORER	32/34/36
	125	420	EXPLORER	32/34/36
	135	350	EXPLORER	34/36/38
	135	370	EXPLORER	34/36/38
	140	300	EXPLORER	36/38/40
	140	350	EXPLORER	36/38/40

ITS080B



Modello Model Modelle	Ø	mt	Irrigatore Raingun Regner	Bocchigli Nozzles Düsen
ITS080B	100	650	RANGER	26/28/30
	110	600	RANGER	24/26/28
	120	540	EXPLORER	30/32/34
	125	450	EXPLORER	32/34/36
	125	500	EXPLORER	32/34/36
	135	400	EXPLORER	34/36/38
	140	380	EXPLORER	36/38/40
	150	300	EXPLORER	36/38/40

Accessori non inclusi - Accessories not included - Zubehör nicht inbegriffen

ITS090B



marani-italy.com

Modello Model Modelle	Ø	mt	Irrigatore Raingun Regner	Bocchigli Nozzles Düsen
ITS090B	110	650	RANGER	24/26/28
	110	700	RANGER	26/28/30
	120	600	EXPLORER	28/30/32
	120	650	EXPLORER	28/30/32
	125	550	EXPLORER	32/34/36
	125	600	EXPLORER	30/32/34
	135	500	EXPLORER	34/36/38
	140	450	EXPLORER	34/36/38
	140	470	EXPLORER	34/36/38
	150	380	EXPLORER	36/38/40

Accessori non inclusi - Accessories not included - Zubehör nicht inbegriffen

IT100B



Modello Model Modelle	Ø	mt	Irrigatore Raingun Regner	Bocchigli Nozzles Düsen
IT100B	125	650	EXPLORER	30/32/34
	125	700	EXPLORER	28/30/32
	125	720	EXPLORER	28/30/32
	125	750	EXPLORER	28/30/32
	135	600	EXPLORER	34/36/38
	135	650	EXPLORER	32/34/36
	135	700	EXPLORER	32/34/36
	140	500	EXPLORER	34/36/38
	140	550	EXPLORER	34/36/38
	140	600	EXPLORER	34/36/38
	150	450	EXPLORER	36/38/40
	150	500	EXPLORER	36/38/40
	150	550	EXPLORER	36/38/40
	150	600	EXPLORER	36/38/40
	160	440	MASTER	38/40/42
	160	480	MASTER	38/40/42

Accessori non inclusi - Accessories not included - Zubehör nicht inbegriffen

BUILT-IN MOTORPUMP



marani-italy.com

Su richiesta le macchine IT060B, IT070B, ITS080B, ITS090B e IT100B possono essere dotate sia di motopompe incorporate per pescare direttamente dai canali o di piccole motopompe di rilancio se la macchina deve lavorare allacciata a delle condotte in bassa pressione.

Le macchine possono inoltre essere fornite con un piccolo motore diesel o benzina per il recupero del tubo e per i servocomandi idraulici.

On request IT060B, IT070B, ITS080B, ITS090B and IT100B machines can be fitted with either a suitably rated motor-pump for drawing directly from the canal or by small booster pumps in case the machine is connected to low pressure mains.

The machines can be fitted with a small Diesel engine with the only function of hydraulic servo controls and for rewinding the hose.

Auf Anfrage können die Anlagen IT060B, IT070B, ITS080B, ITS090B und IT100B mit eingebauten Motorpumpen für die direkte Wasserentnahme aus Gräben oder mit kleinen Motorpumpen, wenn die Anlage an Niederdruckleitungen angeschlossen ist, ausgerüstet werden.

Die Anlagen können des weiteren mit einem kleinen Diesel- oder Benzinmotor für den Schlaucheinzug und die hydraulischen Servosteuerungen ausgerüstet werden.

MACHINE DIMENSIONS



F010B 40-43-50-58-63

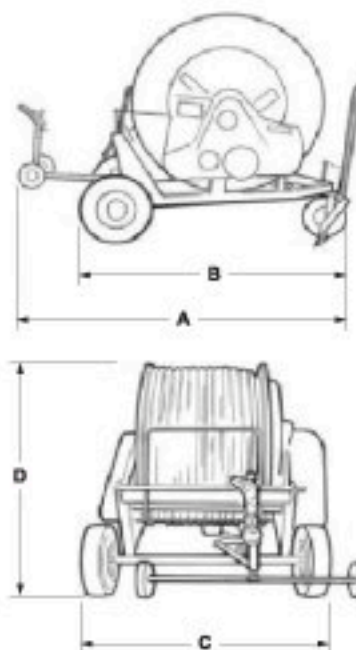

GT015B - GT020B

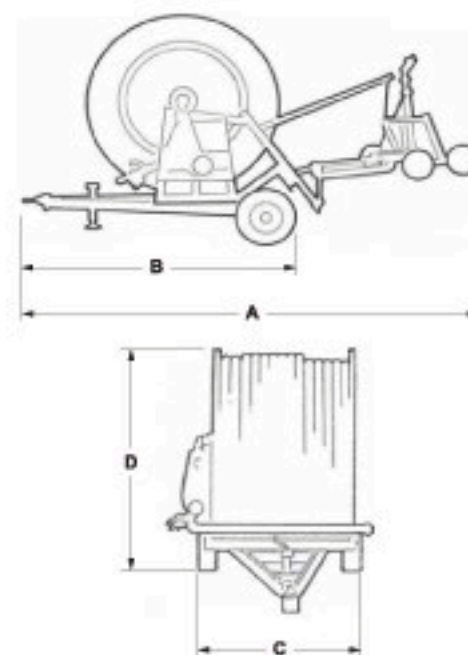

MOD.	A cm.	B cm.	C cm.	D cm.
F010B 40-43	195	150	128	126
F010B 50-58-63	270	190	130	162
GT015B	330	250	130	192
GT020B	460	365	166	220

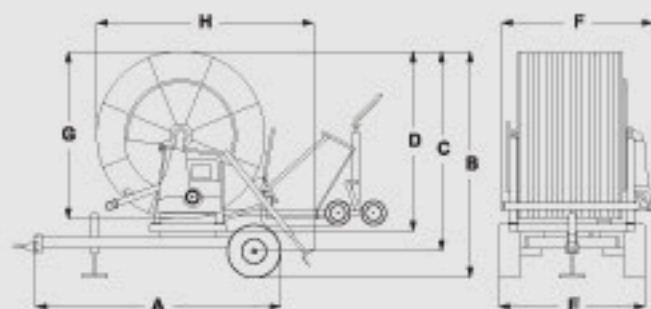

MOD.	A cm.	B cm.	C cm.	D cm.	E cm.	F cm.	G cm.	H cm.
GT022B	310	230	190	184	170	185	169	215
GT026B	340	265	245	225	210	225	199	250
GT030B-GT030C	350	296	265	244	210	225	224	280
GT040B	370	305	286	265	210	225	246	280
GT040C	370	315	297	276	210	225	246	280
GT050B	420	345	310	286	228	240	268	350
GT060B	420	360	333	303	233	250	280	350
GT070B	430	384	357	330	243	260	309	370

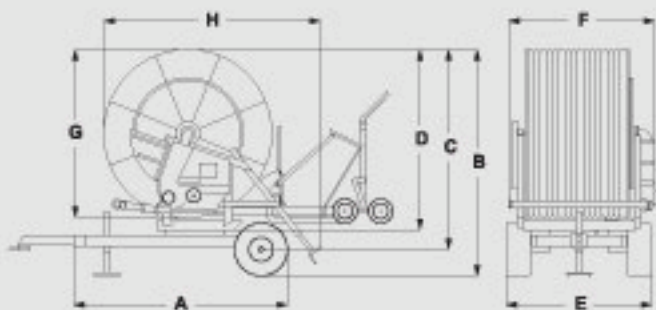

MOD.	A cm.	B cm.	C cm.	D cm.	E cm.	F cm.	G cm.	H cm.
GTS080B	364	403	359	335	240	260	309	350
GTS090B	520	435	400	369	220	243	334	470

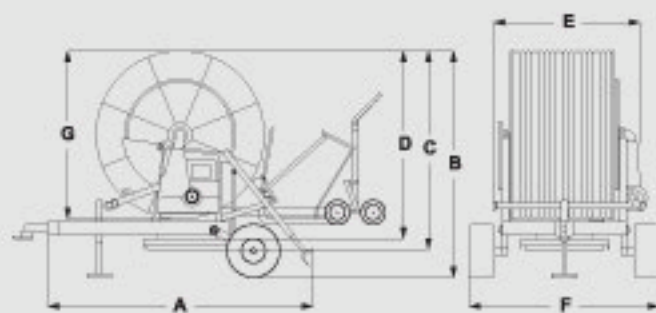

MOD.	A cm.	B cm.	C cm.	D cm.	E cm.	F cm.	G cm.
IT040B	330	308	311	266	220	248	246
IT050B	338	338	309	285	220	255	268
IT060B	367	356	329	307	235	267	280
IT070B	392	383	355	332	240	274	309

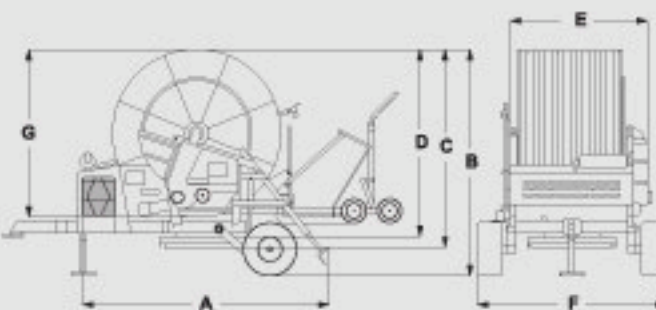

MOD.	A cm.	B cm.	C cm.	D cm.	E cm.	F cm.	G cm.
ITS080B	436	395	362	336	260	282	309
ITS090B	470	430	389	364	218	285	334
IT100B	514	451	419	396	242	303	363

MOD.	A cm.	B cm.	C cm.	D cm.	E cm.	F cm.	G cm.
IT060B	420	366	329	312	269	280	280
IT070B	430	395	358	341	260	280	309
ITS080B	450	395	362	345	260	282	309
ITS090B	530	428	401	388	245	316	369
IT100B	530	438	411	398	245	316	369

ACCESSORIES

1) Valvola di Scarico: valvola di scarico a membrana per lo spegnimento automatico delle stazioni di pompaggio se muniti degli appositi dispositivi di allarme bassa pressione.

1) Discharge Valve: discharge membrane valve for automatic shut-off of the engine pump (pump must have low pressure shut-off).

1) Ablassventil: Membranventil für die automatische Ausschaltung der Pumpstationen bei Installation der entsprechenden Tiefdruck-Alarmvorrichtungen.

2) Valvola di Chiusura: valvola di chiusura lenta azionata da un pistone ad acqua o da un pistone elettrico per chiudere lentamente l'entrata dell'acqua nella macchina.

2) Shut-off Valve: this valve is operated by a water piston or by an electric piston for a slow water shut-off at machine inlet.

2) Absperrventil: Betätigung durch eine Hydro-oder Elektrokolben für eine langsame einlaufseitige Absperrung der Wasser in der Maschine.

3) Compressore per lo Svuotamento: compressore rotativo che consente di vuotare le macchine dall'acqua in 2-4 minuti rendendo di facile impiego anche le macchine di grandi dimensioni.

3) Blow-out Compressor: this enables you to empty the largest hose reels within 2-4 minutes, thus making them easy to transport.

3) Entleerungskompressor: Drehungskompressor für die Wasserentleerung der Anlagen in 2-4 Minuten für eine einfache Bedienung auch von großen Anlagen.



The logo for MARANI, featuring a large, stylized red letter 'M' with the word 'MARANI' in white capital letters inside a red-bordered oval shape.

4) Rotazione e piede timone Idraulico: rotazione e piede timone idraulico azionati da un motore idraulico collegato al trattore o al motore della macchina (se ne è provvista) per facilitare la rotazione delle macchine e per sollevare agevolmente il timone delle macchine più grandi nelle condizioni più gravose di utilizzo.

4) Hydraulic turntable, tongue jack and gun cart lift/stabilizers: operated by a spool valve using tractor hydraulics (or engine if engine drive) for rotating reel, adjusting tongue jack height and lowering/raising gun-cart and stabilizer legs. Ideal for positioning big machines under extreme working conditions.

4) Hydraulische Drehung und Stützfuß mit einem Hydraulikmotor, der mit Schlepper oder dem Maschinenmotor (wenn vorhanden) verkuppelt ist, um die Drehung der Maschine und die Aufhebung des Deichsel auch unter den schwersten Einsatzbedingungen zu erleichtern.



4



5



6



7

marani-italy .com

5) Carrello a 5 ruote srotolamento laterale: carrello a srotolamento laterale del tubo con 5 ruote pneumatiche. Molto indicato in determinate colture e nelle macchine a doppio assale.

5) Off-set trolley: 5 wheel off-set trolley. Ideal for avoiding hose damage to certain crops and standard on most 4 wheel chassis machines.

5) Regnerwagen mit Ablage im Fahrspur: Regnerwagen mit Ablage im Fahrspur mit 5 Luftreifen geeignet für einige Kulturen und auf die Tandemachsemaschinen.

6) Macchina a motore: sistema di riavvolgimento del tubo nella bobina e movimentazione idraulica della macchina, tramite motore (con o senza turbina).

6) Engine Drive Machine: optional hydraulic engine for winding in the hose on the drum and for drive all the hydraulics of the machine (with or without turbine).

6) Schlauchaufwicklung: oder hydraulische Vorrichtung durch Motor (mit oder ohne Turbine).

7) Applicazione secondo irrigatore sul carica carrello con valvola volumetrica.

7) Second gun mounted on the cart lift complete with volumetric valve.

7) Zweiter Regner auf die Aufhebung des Regnerwagen mit volumetrischem Ventil.

COMPUTERS



MARANI

COMPUTER MA-RAIN 36

Con il MA-RAIN 36 si possono programmare le seguenti funzioni di lavoro:

1. Velocità di recupero del carrello porta irrigatore in mt/h e ft/h
2. Pre-impostare il tempo di lavoro determinato per il totale recupero del tubo
3. Scegliere la quantità in millimetri, di pioggia depositata sulla zona irrigata (solo se la macchina è equipaggiata dell' optional Conta litri)
4. Recupero ritardato del carrello porta irrigatore in minuti (pre irrigazione)
5. Comando ritardato delle valvole di apertura o chiusura (optional) in minuti.
6. Possibilità di programmare fino a 4 zone di lavoro con velocità di rientro diverse, sulla stessa fascia irrigata.
7. Possibilità di programmare fino a 4 zone di lavoro con pluviometrie diverse.

Nel display del computer sono inoltre visualizzabili:

1. Metri di tubo PE srotolati ed arrotolati
2. Giorno ed ora di fine lavoro della macchina
3. Portata della macchina in Lit./min. e m³/h erogati (solo con optional conta litri)
4. Velocità di lavoro in mt/h e ft/h
5. Eventuali allarmi con conseguente apertura o chiusura delle valvole di fine lavoro in caso di mal funzionamento e programmazione errata.

Il MA-RAIN 36 può essere collegato ad un modem GSM per la trasmissione a distanza dei dati di lavoro o degli eventuali allarmi.

Il modem trasmette, i seguenti allarmi:

- Mancanza di pressione
- Problema di velocità di recupero del tubo
- Fine lavoro

L'operatore può inviare al modem un messaggio di testo e così facendo può visualizzare sul suo cellulare tutti i parametri di lavoro della macchina.

The compute MA-RAIN 36 features the following programmable functions:

1. Working speed in mt/h and ft/h
2. Working time
3. Choose the amount of precipitation (in mm or inches) to be applied (this feature only available when equipped with optional flow meter)
4. Delayed start (in minutes) before retraction starts.
5. Delayed stop (in minutes) before opening or closing the discharge valve (optional) or the shut-off valve (optional).
6. 4 working zones with different speeds per irrigation run
7. 4 working zones with different application rates per irrigation run (only if the machine is equipped with optional flow meter).

The monitor then indicates:

1. Meters/feet of unwound hose and hose pulled in.
2. Day and time of completion.
3. Flow in lit/min (gpm) and m³/h (only if the machine is equipped with flow meter which is optional).
4. Working speed in mt/h or ft/h.
5. Automatic shut-down in case of mechanical failure or incorrect settings.

MA-RAIN 36 can also be connected to a GSM modem for monitoring and data transmission alarm. The modem shows the following failures:

- No pressure.
- Working speed problems.
- End of the run.

The operator can send a text message to the modem and control all the working parameters of the machine.

Durch den Computer MA-RAIN 36 können die folgenden Funktionen programmiert werden:

1. Einzugsgeschwindigkeit des Regenwagens (in Minuten)
2. Programmierung der Arbeitszeit für die komplette Schlauchaufwicklung
3. Programmierung des Niederschlags (in Millimeter) nur bei Maschinen mit elektronischem Durchflussmesser (Sonderausrüstung)
4. Verzögerte Schlauchaufwicklung am Anfang der Beregnung (Vorberegnung).
5. Verzögerung des Ablass- oder Absperrventils (Sonderausrüstung) in Minuten.
6. Programmierung bis zu 4 Beregnungszonen mit verschiedenen Aufwicklungsgeschwindigkeiten auf demselben Arbeitseinzug
7. Programmierung bis zu 4 Beregnungszonen mit verschiedenen Regenmessungen.

Auf dem Display kann man auch folgendes ablesen:

1. Anzeige der abgerollten und eingezogenen Schlauchlänge
2. Tag und Zeit vom Arbeitseende
3. Durchflussmenge in Lt/Min und M³/h (nur mit Durchflussmenge als Zubehör).
4. Arbeitsgeschwindigkeit in Mt/h.
5. Alarm, beim Öffnen und Schließen der Ventilen im Fall von schlechter Funktion oder falscher Programmierung des Computers.

Der MA-RAIN 36 kann an einem GSM-Modem für die Daten- oder Alarmübertragung angeschlossen werden. Das Modem überträgt die folgenden Alarmen:

- Druckmangel
- Problem mit Geschwindigkeit der Schlauchaufwicklung.
- Arbeitseende

Man kann an das Modem eine SMS senden um all die Arbeitsschritte der Maschine auf dem Handy zu sehen.



COMPUTER MA-RAIN 26

Il programmatore MA-RAIN 26 consente di programmare le seguenti funzioni di lavoro della macchina:

1. Velocità di recupero del carrello porta irrigatore in mt/h e ft/h
2. Recupero ritardato del carrello porta irrigatore in minuti (pre irrigazione)
3. Comando ritardato delle valvole di apertura o chiusura (optional) in minuti.

Nel display del computer sono inoltre visualizzabili:

1. Tempo di lavoro in ore e minuti
2. Velocità di lavoro in mt/h e ft/h
3. Metri di tubo srotolati.

The Computer MA-RAIN 26 features the following programmable functions:

1. Working speed in mt/h or ft/h.
2. Delayed start (in minutes) before retraction starts.
3. Delayed stop (in minutes) before opening or closing the discharge valve (optional) or the shut-off valve (optional).

The monitor then indicates:

1. Remaining working time in hours and minutes.
2. Working speed in mt/h or ft/h.
3. Meters/feet of unwound hose.

Durch den Computer MA-RAIN 26 können folgende Funktionen programmiert werden:

1. Einzugsgeschwindigkeit des Regnerwagens (in Minuten)
2. Verzögerte Schlauchaufwicklung am Anfang der Beregnung (Vorbereitung).
3. Verzögerung des Ablass- oder Absperrventils (Sonderausrüstung) in Minuten.

Auf dem Display kann man auch sehen:

1. Arbeitsgeschwindigkeit in Mt/h.
2. Anzeige der abgerollten und eingezogenen Schlauchlänge
3. Arbeitszeit in Stunden und Minuten.

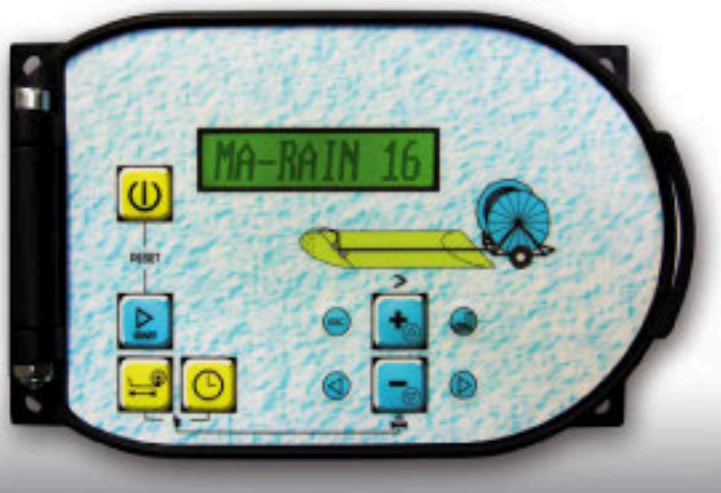

COMPUTER MA-RAIN 16

Il programmatore MA-RAIN consente di programmare la velocità di recupero del carrello porta irrigatore in mt/h e ft/h.

Nel display del computer sono inoltre visualizzabili:

1. Tempo di lavoro in ore e minuti
2. Metri di tubo srotolati.

The Computer MA-RAIN 16 requires programming the desired working speed in mt/h or ft/h.

The monitor then indicates:

1. Remaining working time in hours and minutes.
2. Meters/feet of unwound hose.

Durch den Computer MA-RAIN 16 kann man die Geschwindigkeit der Schlauchaufwicklung in Mt/h programmieren. Auf dem Display des

Computer kann man auch ablesen:

1. Arbeitszeit in Stunden und Minuten
2. Anzeige der abgerollten und eingezogenen Schlauchlänge

MOTORPUMPS



Allestimento standard:

- MOTORE DIESEL a 2,3,4,6 cilindri, raffreddato ad acqua o aria, completo di liquidi di primo riempimento
- CARRELLO trainabile a due ruote pneumatiche con serbatoio incorporato
- POMPA centrifuga flangiata o in linea accoppiata al motore mediante giunto elastico o diretto
- CENTRALINA MAC 1 con impianto elettrico, dispositivo di controllo motore, 1 pressostato manuale bassa pressione, timer
- BATTERIA.

Optional disponibili:

- Tettuccio ABS
- Tettuccio con protezioni laterali motore
- Insonorizzazione completa o solo motore
- Centralina automatica o semi-automatica con trasduttori di pressione
- Regolatore elettrico della velocità motore
- Alzapesca con rotazione ad angolo zincata manuale o idraulico
- Serbatoio maggiorato con capacità fino a 1.480 litri
- Allestimento su base fissa
- Parafanghi in ABS
- Staffe portatubi
- Faro di manovra
- Piede anteriore girevole
- Box Protezione Centralina serie MAC
- Giunto espansione
- Barra illuminazione posteriore
- Ruote 10.0/80 12 8 tele 5 fori
- Dispositivo di adescamento a depressione (Kirpy) o con pompa elettrica
- Raccordi vari in aspirazione e mandata pompa.

Standard equipment:

- ENGINE: 2,3,4,6 water and air cooled diesel engines, completes with first fill liquids
- TROLLEY: 2 pneumatic wheels trolley, with incorporated tank
- PUMP : Centrifugal flanged pump coupled to the engine by flexible joint
- CONTROL PANEL : MAC 1 with electric system, engine control device, 1 manual low pressure switch, 24 hours timer
- BATTERY.

Available accessories:

- ABS Sheet Roof
- Sheet roof with side engine
- Total or only engine soundproofing canopy
- Automatic and semi automatic control panel with pressure transducers
- Electronic speed regulation
- Galvanized adjustable intake with angle rotation manual or hydraulic
- Up-graded frames with capacity up to 1.480 litres
- Unit mounted on fix base
- ABS Mud-guards
- Pipe holder
- Headlights
- Rotating front support foot
- Protection for MAC control panel
- Expansion Joint
- Rear lights system
- Up graded wheels 10.0/80 12 8 PR 5 Holes
- Depression primingf system (kirpy) or with electric pump
- Big range of different available couplings in suction unit as well as delivery unit.

Standard Ausstattung:

- DIESELMOTOR mit 2,3,4,6 Zylindern, wasser- oder luftgekühlt, komplett mit Flüssigkeiten für die erste Zylinderfüllung
- Ziehbarer WAGEN mit 2 pneumatischen Rädern mit eingebautem Tank
- Angeflanschte und in Linie ZENTRIFUGALPUMPE verkuppelt mit dem Motor durch eine elastische oder direkte Kupplung
- STEUERGERÄT MAC1 mit Elektroanlage, Motorkontrollvorrichtung, 1 manuellen Niederdruck Druckschalter, Zeitschaltuhr
- BATTERIE.

Verfügbares Zubehör:

- ABS Dach
- Dach mit Seitenmotorverkleidung
- Komplette Schalldämmung oder nur Motor-Schalldämmung
- Automatisches oder halbautomatisches Steuergerät mit Drucksgeber
- Elektrischer Regler der Motorgeschwindigkeit
- Manuelle oder hydraulische verzinkte Anhebevorrichtung mit Winkelrotation
- Vergrößerter Tank mit Kapazität bis zu 1.480 Lt
- Ausstattung auf fester Basis
- ABS Kotflügel
- Rohrschellen
- Steuerung Scheinwerfer
- Vorderfuß drehbar
- Schutzkasten für Steuergerät Serie MAC
- Dehnungsfuge
- Hinten Lichtstange
- Räder 10.0/80 12 8 Lagen 5 Löcher
- Ansaugvorrichtung mit Saugdruck (Kirpy) oder mit elektrischer Pumpe
- Verschiedene Anschlüsse in Ansaugung und Pumpe-Förderleistung.

Le motopompe sono disponibili in vari allestimenti.

Pump sets are available in various optional versions.

Die Motorpumpenaggregate sind verfügbar in verschiedenen Ausführungen.



marani-italy.com

PUMPS

POMPE CENTRIFUGHE A
TRATTORE PER ACQUA E LIQUAMI

CENTRIFUGAL PUMPS FOR
WATER AND SLURRY

ZENTRIGUGALPUMPE FÜR GÜLLE
UND WASSER

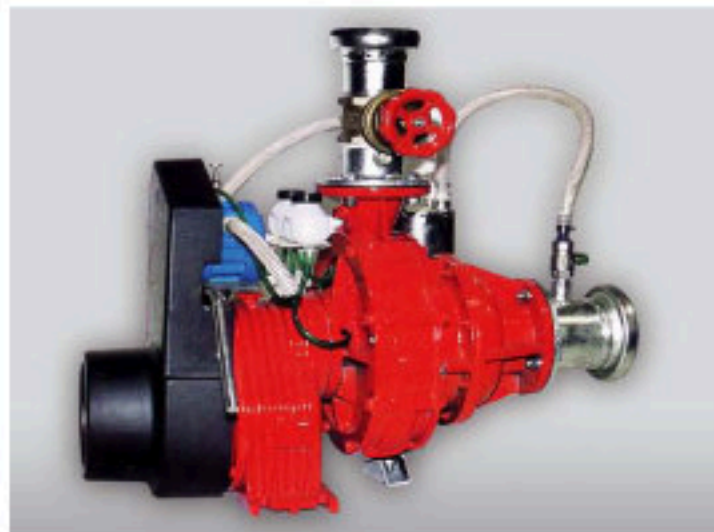

M
MARANI
M

PUMPS HYDRANT BENDS AND HEADS

TESTE E CURVE DI IDRANTE

HYDRANT BENDS AND HEADS

HYDRANTEN-KÖPFE UND
KURVEN FÜR HYDRANTEN



marani-italy.com

► GENERAL CATALOGUE ◀



marani irrigation



MARANI IRRIGAZIONE SRL
Via Scaglia Est, 5 - 41100 Modena - ITALY
Tel. +39 059 702 304 - Fax +39 059 490 67 18
info@marani-italy.com - www.marani-italy.com